



## Michigan Dirt Late Model Rules 2025 Season

**The following rules have been approved for racing at the following Michigan Dirt tracks: Crystal Motor Speedway, Thunderbird Raceway.**

The rules and/or regulations set forth herein are designed to provide for the orderly conduct of racing events and to establish minimum acceptable requirements for such events. These rules shall govern the condition of all events, and by participating in these events, all participants are deemed to have complied with these rules.

NO EXPRESSED OR IMPLIED WARRANTY OF SAFETY SHALL RESULT FROM PUBLICATIONS OF OR COMPLIANCE WITH THESE RULES AND/OR REGULATIONS. They are intended as a guide for the conduct of the sport and are in no way a guarantee against injury or death to a participant, spectator or official.

The race director shall be empowered to permit reasonable and appropriate deviation from any of the specifications herein or impose any further restrictions that in his opinion do not alter the minimum acceptable requirements. NO EXPRESSED OR IMPLIED WARRANTY OF SAFETY SHALL RESULT FROM SUCH ALTERATION OF SPECIFICATIONS. Any interpretation or deviation of these rules is left to the discretion of the officials. Their decision is final.

### **2025 American Racer PRO 3SPEC JPED6 – 88 or American Racer Pro 3SPEC JPE2A – 92, will be allowed for regular race nights**

#### **1. ENGINE**

Only conventional type V-8 engines with the cam in the block will be permitted. There will be no limit on the cubic inch displacement. All engines must be based on a manufactured, factory design. Aluminum or steel blocks will be permitted. All engines must be normally aspirated with a single conventional-type four (4) barrel carburetor. The engine must have an operating self-starting mechanism. Vehicles that require a 'push start' will not be permitted. Only a single distributor and magneto will be permitted. Coil pack and/or engines that have individual ignition systems, electronic or mechanical for each cylinder will not be permitted (exception is if the engine is a sealed CT525 crate engine). A maximum of 25 1/2"-inches from the center of the ball joint to the front of the motor plate/engine bell housing flange will be permitted. Only two valves and one spark plug will be permitted per cylinder.

## 2. TRANSMISSION AND DRIVELINE

Direct drives systems of any-type will not be permitted. The transmission must be bolted to the engine it must have forward and working reverse gear(s) and must be able to shift to forward or reverse with engine running. All cars must be equipped with a working self-starter. The driveshaft must be a minimum of 2" inches in diameter. All drive shafts must be painted white. Only one drive shaft connected from the transmission to the center section of the rear end will be permitted. A minimum of one driveshaft hoop / sling must be fastened securely to the frame. It is recommended that two driveshaft hoops / slings be used.

Any type of rear end differential / center section will be permitted. Live-axle type rear ends will not be permitted. Independent rear suspensions will not be permitted. Floater-type wide-five hub assemblies will be the only hub assemblies permitted.

The axle housing must be of the "closed tube" design utilizing "full floating" magnetic steel axle shafts. The center section of the axle housing must be manufactured of either aluminum or magnesium.

Axle tubes must be one (1) piece. Axle tubes must be manufactured of aluminum or magnetic mild steel. Axle tubes manufactured of exotic; heavy materials will not be permitted. The outside diameter of the axle tubes must not exceed three (3) inches. Axle tube internal inserts or external sleeves will not be permitted. The addition of any ballast weight to the axle housing will not be permitted.

## 3. FUEL SYSTEM

All cars must have fuel cells that meet and/or exceed the FIA / FT3 specifications. Fuel cells must be used in accordance with the FT3 specifications. The fuel cell may have a maximum capacity of 35 gallons. The fuel cell must be enclosed completely in a container that is a minimum thickness of 20-gauge magnetic steel and/or .060"-inch aluminum. The entire container must be visible for ease of inspection. If fuel cell does not have aircraft style positive seal filler neck/cap system - a flapper, spring or ball type filler rollover valve is required.

The fuel cell must be mounted behind the rear axle between the rear tires, a minimum of 4"-inches ahead of the rear bumper. The bottom of the fuel cell must not be any lower than the bottom of the rear end/quick change housing. The fuel cell must be mounted either in a welded steel tubing "rack" or with a minimum of two (2) equally spaced .125"-inch thick steel straps that measure two (2) inches wide. The straps must cover the entire cell, be bolted to frame. Longitudinal (front to rear) orientation is recommended for strap mounting. A minimum of 7/16"-inch ASTM Grade 8 bolts must be used to mount the fuel cell to the frame.

The fuel pick up must be positioned on the top (recommended) or right side of the fuel cell and be constructed of steel. The fuel pick up must have a check valve. Only racing gasoline or alcohol will be permitted for competition. Nitrous oxide, nitro-methane and/or propylene oxide will not be permitted. For the purpose of inspection, the driver and/or crew must be prepared to drain fuel upon request for inspection and/or measurement. Only mechanical and/or belt driven fuel pumps will be permitted. Fuel injection system(s) and/or electrical fuel pumps and/or any type of pressurized fuel system will not be permitted. Willy's Carburetor roll over plate part # WCD4000 is approved for competition. **A fuel shut off valve is required on each car. "Fuel Shut Off" securely mounted and easily accessible. The Michigan Dirt Track Inspector has final decision on mounting of shut off valve.**

**See below page for fuel shut off options:**

**If running a ball valve: A fuel shut off ball valve is required to be within reach of driver and safety crew and to be mounted with the handle through the deck or firewall not to be mounted inside the cockpit. The valve and handle must be painted bright orange, and clearly labeled with "Fuel Shut Off" securely mounted and easily accessible.**

**If running an Oberg Valve: An Oberg Fuel Line Safety Valve is required to be installed under body/deck and behind firewalls, in the fuel line and per manufacture instructions; not to be mounted inside the cockpit. The valve must be securely mounted and easily accessible for**

inspection. Car must be clearly labeled with "Oberg Fuel Valve" composed of a vinyl sticker (1" stroke orange letters with a white 1/2" outline) sticker must contrast from body and graphics to be easily readable. Two stickers will be required; one on the deck where the ball valve would have been mounted and one on the fuel cell or on the trunk lid.

#### 4. EXHAUST

The exhaust flow must be parallel to the ground. Exhaust systems that direct the flow toward the ground will not be permitted. All exhaust systems/headers must end with a collector. Muffler is mandatory maximum of 98 decibels at 100 feet. If you can't meet the 98 DB limit, the track may require a specific muffler. Recommended mufflers: Allstar #ALL34160, BEYEA #MUF3.5, Dynatech #776-06352 or #776-24352, Hushpower #135161, Schoenfeld #1427273578, Speedway #910-13984

#### 5. TRACTION CONTROL

All electronic and/or computerized wheel spin and/or ignition retardation and/or acceleration limiting and/or traction control devices of any type will not be permitted. Adjustable ping control devices, dial a chip controls, timing controls and/or automated throttle controls will not be permitted. Adjustable restrictor plates will not be permitted. Remote control components of any-type will not be permitted. Radios and/or devices for transmitting voice and/or data will not be permitted. Data acquisition systems will not be permitted. All ignition system wires must be visible for inspection.

#### 6. FRAME

The wheelbase minimum will be 103"-inches with a maximum wheel base of 105"-inches. All frames must be fabricated from magnetic steel with a minimum of 2"-inches x 2"-inches or approved rectangular magnetic steel with a minimum material thickness of .083"-inches. A minimum of 1.75" Outside Diameter magnetic steel tubing, 4130 Chrome Moly with a minimum material thickness of .083"-inches or DOM with a minimum material thickness of .095"-inches, will be permitted for frames that are fabricated from round tubing.

Rear bumpers that are stubbed may only extend a maximum of 8"-inches beyond the frame. Any stubbed rear bumper that extends further than the maximum of 8"-inches must be formed and directed 8"-inches toward the front of the car. External rub rails will not be permitted. All cars must be equipped with a tow hook and/or strap for the purpose of towing.

Any frame built on or after January 1st, 2006, must have the builder's unique serial number plate prominently attached to the left side roll cage upright. The plate must be welded in place. All characters on the plate must be a minimum of 1/2"-inch in height and the serial number must not exceed 8 characters.

#### 7. WEIGHT

The total weight of the car with the driver will be:

A minimum of **2,300 lbs.** as weighed on the track scales at the end of any race.

Weights up to 50 lbs. must be positively fastened by 2, 1/2-inch minimum, grade 5 bolts with a minimum of two weight clamps. Threaded rods will not be permitted. All weights must be painted white and clearly labeled with the car number on it. Any weight(s) must be securely attached to the frame below the body decking. Any car that loses any weight/ballast during an event may be subject to a penalty. Weights attached to the rear bumper and/or outside the frame will not be permitted. Pellet-type and/or liquid-type weight/ballast will not be permitted. Driver operated weight adjustment, 'weight jacking' devices will not be permitted.

#### 8. OVERALL APPEARANCE

The car must be neat in appearance and must display the car number on the front nose and the rear fuel cell. The minimum height for the number will be 6"-inches. The car must have legible numbers on each side and on the roof a minimum of 18"-inches high, the driver's last name must be placed in legible letters on passenger and driver doors or rocker panels.

## 9. BODY

(SEE DIAGRAMS 1-5)

The nosepiece must match the body style of the make and manufacturer of the car and be the same as the make and manufacturer of the motor (GM, Ford, Mopar). All cars must have a minimum half-inch (1/2") and a maximum of one -inch radius at the top of fenders, doors and quarter panels. Sharp edge(s) will not be permitted. The floor boards and firewall must completely cover the driver's area with no openings. Fins and/or lips of any-type will not be permitted anywhere along the entire length of the car. The body line must be a smooth even line from front to rear. Wedge shape cars and/or body styles will not be permitted. "Belly pans" or any type of enclosure on the bottom of the car will not be permitted. A skid plate to protect the oil pan is permitted. A maximum 1/8" skid plate will be permitted. Wings and/or tunnels and/or any type of air deflection device will not be permitted underneath the body and/or chassis of the car. A maximum of one stone deflector, for rear mounted oil pumps, oil filters, and for the main oil tank will be permitted. The deflector may be made of steel, aluminum, or heavy gauge wire. The cover may only be mounted near the unit it is designed to protect with a maximum size of 18" x18" and only mounted from the upper right frame rail to the lower right frame rail. Panels of any type under the rear deck running from the front to the rear of the car will not be permitted. **Bodies that are non-approved will be assessed a weight penalty. The minimum weight penalty will be as follows; 25 lbs. per inch of the infraction.**

Any style air cleaner scoop used must be positioned in front of/or around the air cleaner and must not exceed 1"-inch in height above any part of the air cleaner. Any type of flange and/or air deflection device and/or fin that is designed to direct airflow will not be permitted. Cockpit adjustable components with the exception of brake bias adjusters will not be permitted. Adjusters of any-type, including but not limited to adjustable shocks, hydraulic or pneumatic weight jacks, trackers, ignition boxes or similar adjustable components will not be permitted inside the cockpit of the car or within reach of the seated driver.

The top edge, measured from the ground, of the rear quarter, door and front fender to the point where the fender flare attaches must be a straight line, within one inch on both sides of the car

## 10. NOSE PIECE

Only the following approved nosepieces may be used; Dominator, MD3 - Performance Bodies, ARP Air Speed Nose, Five-Star MD3 type, Performance Bodies/Five Star MD3 2015, Performance Bodies/Five Star 2016 Evolution, Performance Bodies/Five Star 2019 Evolution 2

Approved nose assemblies must be installed per the manufacturer's instructions. All nose assemblies must meet the maximum/minimum dimensions, shall maintain manufacture appearance and not be altered. Front nose assemblies, not meeting the maximum/minimum dimensions, at the series discretion, may be permitted to compete as a "non-conforming" nose with a minimum of 50 additional pounds mounted in front of the motor plate. At series discretion, degree on non-compliance may require additional weight and/or placement of penalty weight in front of radiator.

All nosepieces must be made of molded type material. Nose filler panel shall be flat across to entire surface, dishing or raising prohibited. Two-piece noses must be positively fastened together in the center. Spacers added to gain width will not be permitted. The nosepiece must be mounted in a manner that does not alter its original shape. The nose shall remain flat above the nose lip/wicker bill. Alterations and/or additions made to this area other than cooling holes will not be permitted. The nosepiece can extend a maximum of fifty-three inches (53") from the center of the front hub to the farthest point extending forward. The nosepiece must display a headlight decal package. A one-race grace period, running contrasting color tape in the shape of a headlight will be permitted.

Right Side Nose Height Rule – The maximum height from the ground to the top of the nose splitter shall be 15 inches. Front nose must be mounted in the center of the car.

## 11. ROOF

The roof length from front-to-back must be a minimum of 44"-inches with a maximum of 54" inches. The roof width from side-to-side must be a minimum of 48"-inches to a maximum of 52"-inches. The roof must be stock appearing and be mounted level to the body. The minimum height of the roof will be 45"-inches with a maximum height of 48"-inches. The roof must be mounted parallel to the body and near the center of the car as viewed from the front of the car. A maximum 1-1/2" roll, turned downward will be permitted along the front edge of the roof. A maximum 1"-inch roll, turned downward, will be permitted along the rear edge of the roof. These modifications will be permitted to improve the strength of the roof. Any other modifications to the roof will not be permitted. Flat and/or odd shaped roofs will not be permitted. Bellied and hollowed roofs will not be permitted. Any sun/antiglare shields may not exceed a 4" drop from the top roof line and must hinge for easy exiting. A maximum of two roof edge bead rolls of a maximum height of 1/2"-inch the length of the roof will be permitted. The roof posts and spoiler support(s) may not overlap. Only single plated roofs will be permitted. The maximum thickness of the roof at any point will be 1/2"-inch. The roll cage and associated frame members above the interior panels (decking) must remain open. Enclosures will not be permitted.

## 12. ROOF SUPPORTS AND WINDOW SIDE PANELS

All roof side panels must extend to the edge of the body. The roof side panel window size must be a minimum of 10"-inches x 15"-inches and must match drawing number -2- side view. A maximum crown of two inches will be permitted, measured from the center of a common tangent point on either side of the crown. The side window area may be covered with clear Lexan and/or equivalent type material, be cut out and/or represented by a decal. Both roof support openings must be covered and/or both must be left open. The left and right side openings must be the same size with a tolerance of one inch. The left and right-side window panels must match. A maximum bow of two (2")-inches outward on the window side panels as viewed from behind will be permitted. The front roof supports up to 2"-inches in width must extend forward to the rear of the hood. Front roof supports may be a maximum of 4" wide. Left and right front roof supports must match.

## 13. FRONT FENDERS, FENDER FLARES, AND HOOD

The hood and the front fenders must be level and flat from the left to the right side of the car. The front fenders can be a maximum of 2 inches off center from left to right. No bubble fenders allowed. The outside edges of the hood and/or the fender must remain inside the overall bodyline. The front fender may be a maximum of 37"-inches in height, measured vertically from the ground to the top of the fender behind the front tires. The front fender flares must be made of plastic and must not alter the original shape of the nose piece. The front fender flares must not extend beyond the front tires more than 1"-inch per side to a maximum width, edge-to-edge, of 90"-inches in width with the wheels pointed straight. The front fender flares must be flat across the entire width of the car. Front fender flairs shall not extend, bubble or rise more than a maximum of four inches (4") at any point of the front fenders and/or hood. The front fender flares must have collapsible supports. All cars must have FULL FENDER TOPS. The front fender may be a maximum of 37"-inches in height, measured vertically from the ground to the top of the fender behind the front tires and at the right front fender and door area at the T-Bar.

## 14. DOORS

The door-to-door measurement must not exceed 76"-inches in width at the top of the doors. The door-to-door measurement must not exceed 90"-inches in width when measured at the bottom of the doors in the center of the car. The doors must not exceed 37"-inches in height when measured from the ground to the top of the door. The door sides may not break inward from the top 76"-inches and bottom 82"-inch measurements. Hollow and/or belled doors will not be permitted. The minimum ground clearance will be 3" inches.

## 15. QUARTER PANELS

The maximum distance from the center of the rear hub to the top rear of the quarter panel is 53"-inches. The quarter panels must not exceed 76"-inches in width at any point as measured at the top of the panels. The rear deck must taper in a symmetrical manner from the center of the rear hub to the rear spoiler with a minimum width of 72"-inches and a maximum width of 76"-inches. The maximum width for the quarter panels

measured from outside-to-outside measured 19"-inches from the ground and/or at the bottom of the quarter panel will be 86"-inches. Any breaks and/or bends formed in the sides of the quarter panel that move the panel toward the center of the car will not be permitted. Hollow and/or bellied panels will not be permitted. The maximum distance from the center of the rear hub to the rear trailing edge of the quarter panel will be 49"-inches. A minimum of 2"-inches of tire clearance between the tire and the body will be required. Skirting that extends behind the rear quarter panel will not be permitted. Plastic Quarter panels allowed right side only.

Left rear quarter panels must extend downward from the deck a minimum of 33" and maximum of 36", including plastic when measured at the front and rear of quarter panel. Right rear quarter panel must extend downward from the deck 27" without plastic, or 31" with plastic when measured front to rear.

## 16. SPOILER

Only aluminum and/or Lexan and/or Lexan-type rear spoilers will be permitted. The maximum overall height of the rear spoiler will be 8"-inches. The maximum width of the rear spoiler, including braces and/or supports is 72"-inches. The rear spoiler must begin at the deck and extend 8"-inches from that point. Suspending the spoiler to create a wing-type device will not be permitted. The rear spoiler must begin at the rear most point of the quarter panels. Only three spoiler braces/supports will be permitted. The front edge of the spoiler brace/support must be in line with the spoiler. The outside spoiler supports must not be mounted any-wider than the top of the quarter panel(s) and must be centered on the rear deck. In the event that aluminum angle is used to bracer the upper edge of the spoiler, the angle must not add to the height and/or length of the spoiler in any way.

## 17. INTERIOR

The interior of the cockpit must be a minimum of 11"-inches below the top of the roof and/or roll cage, measured perpendicular to the ground from the bottom of the roof to the cockpit deck. Roof rolls are not part of the measurement. The side window opening(s) must be 15"-inches from the top of the door to the bottom of the roof. Supports bars that block the right window from the driver exiting the cockpit will not be permitted. A rock guard (Lexan screen) can be no higher than 4 inches, and no farther back than the front edge of the right-side head rest. If the interior deck drops the drop must begin at the rear of the engine plate with a maximum of 4" inches and must not drop below 4"-inches rear of the hood. The start of the dropped interior must remain closed as a part of the fire wall. The entire width must be closed off with sheet metal. The interior must gradually taper up to the quarter panel height and must be level for a minimum of 20" inches from the rear of the quarter panel and deck.

## 18. DRIVER COMPARTMENT

A full metal firewall fabricated from magnetic steel and/or aluminum must encompass the driver's compartment from front-to-rear, on both sides and floor boards. The driver's seat must be a high back aluminum seat, designed specifically for racing, located on the left side of the car and mounted per the manufacturer's instructions securely to the frame. The seat design should be one from a current manufacturer and/or recommended to include the full containment design. Installation of the full containment seat should follow the manufacturer's instructions. All cars must be equipped with a quick-release type steering wheel that is a full circle. The driver compartment must have a starting switch and/or button within reach of the driver. A clearly labeled electrical on/off ignition 'kill' switch must be to the right of the driver and within drivers reach. Mirrors of any-type will not be permitted. Radios and/or electronic and/or data communication devices will not be permitted. Any edge and/or sheet metal end in and around the driver compartment must be protected with trim and/or beading and rounded. Sharp and protruding edges will not be permitted. A substantial rock guard with a minimum of three additional roll bars must be mounted in front of the driver. The rock guard must be made from wire screen. Windshield screens must be a minimum of .090-inches and must be securely fastened.

## 19. BRAKES

All cars must be equipped with an operating four-wheel disc brake system. Brake rotors must be manufactured of magnetic or stainless steel. **Brake lines must be visible for inspection.**

**The combined weight of the wheel hub, wheel bearings and seal, spindle nut and washers, brake rotor and attaching hardware, the axle cap, and the wheel spacer must not exceed 27 pounds.**

## 20. SHOCK ABSORBERS

Mono-tube, single piston, nitrogen gas charged shocks will be permitted. All shocks must utilize mechanical oil controls, such as: spring shim(s), drum and disc(s), check ball and spring, needle and seat for internal and external shock adjustments. Magnetic and/or electro-magnetic controls are not permitted. Remote nitrogen gas reservoirs will be permitted. The remote reservoirs may contain a compression adjustor. Adjustments described above are the only shock adjustments that will be permitted.

Shock adjustments while the vehicle is in motion will not be permitted. Shocks and shock components may only be manufactured from steel or aluminum. Rotating parts will not be permitted inside or mounted to the shock absorber. Inertia/gyro style shocks are not permitted. Thru-rod shocks will not be permitted. Unless otherwise authorized, all shocks must be mounted as close to vertical as possible.

Approved shock locations are as follows:

One (1) shock will be permitted at each front wheel.

One (1) shock will be permitted at the right rear wheel.

Two (2) shocks will be permitted at the left rear wheel. When using only one (1) shock at the left rear wheel, the shock must be mounted behind the rear axle tube. When two (2) shocks are used at the left rear wheel, one (1) shock must be mounted behind the rear axle tube and the second shock must be mounted on top of or forward of the rear axle tube.

One (1) shock will be permitted mid-ship at the front of the lift arm assembly.

One (1) braking shock will be permitted. The shock must be mounted within three (3) inches of the center line of the rear axle center section. This shock must be mounted horizontally. Air shocks are permitted.

Thru-rod shocks will not be permitted.

. Shock shaft can't exit both sides of the oil volume.. Any shock with the dampening piston mounted more than one and one half (1.5) inches beyond the end of shock shaft, allowing the shaft to pass thru the main body on both ends simultaneously, will be classified as thru-rod or thru-shaft shock.

## 21. SUSPENSION

General:

Any and all new designs or modifications to an existing suspension and/or suspension component must be communicated to and approved by the Series Director before being used in competition. Rear suspension must utilize either coil or leaf springs. Rear suspension configuration used on current and new chassis(s) must be the design commonly known as four (4) link. Older cars currently competing with other rear suspension designs will be allowed to compete until further notification at the discretion of the Track Inspector. In regard to swing arm and/or Z-Link suspension, these suspension types are permitted. The shock on a swing arm or zlink rear suspension may mount to the bird cage or bottom radius rod. Top and bottom solid links must be mounted on hiems and run in the opposite direction of bird cage. Bump sticks are not allowed anywhere on the car.

Axle Housing, Rear Differential:

The axle housing must be of the "closed tube" design utilizing "full floating" magnetic steel axle shafts. The center section of the axle housing must be manufactured of either aluminum or magnesium. Axle tubes must be one (1) piece. Axle tubes must be manufactured of aluminum or magnetic mild steel. Axle tubes

manufactured of exotic; heavy materials will not be permitted. The outside diameter of the axle tubes must not exceed three (3) inches. Axle tube internal inserts or external sleeves will not be permitted. The addition of any ballast weight to the axle housing will not be permitted. Axle tube, including axle tube sleeves, donuts, or added parts may not exceed (3) three inches O.D. (outside diameter) at any point from center section to hub.

#### Rear Suspension Frame Mounts:

The frame/roll cage structure must have integral welded mounting brackets for the attachment of rear suspension components. Frame suspension mounts may be welded or bolted securely (without any movement) to the frame/roll cage structure. The only materials used to fabricate frame suspension mounts that will be permitted are magnetic steel or aluminum. Frame suspension mounts may be either a single or double shear configuration for mounting suspension components. Single shear frame suspension mounts must be a minimum of 1/4 inch in thickness. Double shear frame suspension mounts must be a minimum of 3/16-inch thickness on both sides of the mount. All frame suspension mount component mounting holes must be round and sized correctly for the fastener being used. Clearance between the fastener and the mounting hole must not exceed the next fractional drill size. Example: 1/2-inch fastener, 33/64-inch mounting hole.

#### Axle Housing Mounts:

Only one (1) axle-housing mount per side will be permitted. The only materials used to fabricate axle housing mounts (birdcages) that will be permitted is aluminum or magnetic mild steel. Axle housing mounts fabricated of exotic; heavy materials will not be permitted. When fabricating axle housing mounts detail must be paid to functionality. The completed axle housing mounts, when comparing the right and the left side, must be as similar in design as possible. Axle housing mounts may be a solid (welded) type or a floating type (birdcage) design. The final assembled axle-housing mount must be a one (1)-piece mount. When a floating type mount (birdcage) is fabricated using two (2) pieces, the two (2) pieces must create a common one (1)-piece pivot (barrel). The two (2) pieces must be fastened or welded together to prevent independent movement of the two (2) pieces. The axle-housing mount must attach directly to the axle tube with clearance only to permit rotation of the entire mount. Fore, aft or vertical movement of the mount or the axle housing within the mount will not be permitted. Mounts for suspension attaching (radius) rods must be an integral part of the axle housing mount. The mounts may be either a single or double shear configuration. When using a single shear configuration, a minimum thickness of 1/4 inch for magnetic steel or 1/2 inch for aluminum is required. When using a double shear configuration, a minimum thickness of 3/16 inch for magnetic steel or 1/4 inch for aluminum is required. Dynamic movement of any mount other than a rotational and pivoting movement as a result of suspension travel will not be permitted. Unless otherwise authorized by the Track Inspector, the mounting of any component(s) other than suspension attaching (radius) rods or shocks will not be permitted on the axle housing mounts.

#### Rear Suspension Attaching (Radius) Rods:

A maximum of two (2) attaching (radius) rods per side will be permitted. The only materials used to fabricate attaching (radius) rods that will be permitted are magnetic steel or aluminum. Attaching (radius) rods may be solid or tubular material. The material may be round or hexagon in shape. Spherical rod ends, or steel clevises must be used at the end of each rod for pivoting, static length adjustment, and mounting. Bushings of any type will not be permitted. The final assembled attaching (radius) rod must not have the capability to change length dynamically by any means or devices. Spherical rod end sizes may be a minimum of a 5/8-inch rod end body with a 1/2-inch bearing to a maximum of a 3/4-inch rod end body with a 3/4-inch bearing. In all applications, the correct size fastener must be used when mounting the spherical rod end to a bracket (example: 1/2-inch fastener must be used with a 1/2-inch bearing and mounting hole). Metal step spacers will be permitted to reduce the hole size of the spherical rod end bearing. Attaching (radius) rods must mount directly to the frame suspension mount at the forward end and to the axle-housing mount at the rearward end. All rear suspension fastener must be magnetic steel with a minimum diameter of 1/2 inch. The use of grade 8 fasteners is highly recommended. All fasteners must be correctly sized for the component and application of use. When rear suspension assembly is completed, the attaching (radius) rods must have a minimum of eight (8) inches between the pivots at both the frame suspension mount and the rear axle-housing mount.



### Rear Travel Limiter (Droop Rule)

- a.** A vertical travel limiting chain must be installed on the left rear of the car from the left rear axle housing to the frame. The travel limiting chain must attach to a bearing type mount or a clamp mounted bracket with the chain mounted to the top (12 o'clock) of the left rear axle tube, between the birdcage and the edge of the left rear bell of the axle housing, and to the left rear frame directly above the chain mount on the rear axle. Travel limiting chains must be installed so that when taunt they are as close to vertical as possible. One (1) compliance device may be used. The compliance device must not be more than one inch (1") thick (without a load applied) and remain completely open and visible. Compliance devices can be rubber or any like material but must not be installed in any type of canister. Springs, spring-loaded, and/or pneumatic devices will not be permitted. No tapered, beveled, or roller skate type of compliance rubber will be permitted. Compliance devices must be solid material, same diameter top to bottom, not hollowed or drilled to soften the material.
- b.** The travel limiting chain including the compliance rubber must be installed so that when the car is jacked up from the rear the chain assembly is tight (no slack). The travel limiting chain is subject to inspection at any time during the event at the discretion of the officials. Cars will be jacked up on the under-slung frame rail between the center of the rear axle and the Panhard bar mount. The left rear under-slung rail must be located between the left rear birdcage and the edge of the left rear axle housing bell. If a chassis is not of the under-slung design, then the car will be jacked up on the left rear frame rail closest to the Panhard bar mount. Cars will be jacked up until a forty-thousandths of an inch (.040") shim will slide between the left rear tire and the ground. Once the car is jacked up as described a vertical measurement will be taken from the ground to the top trailing edge of the rear deck bar, six inches (6") inboard of the left rear quarter panel outer edge. The measurement must not exceed fifty-one inches (51"). (Cars without a left rear underslung must not exceed fifty inches (50")).
- c.** All droop limiter assemblies must support the unsprung mass of the rear-end. The stretched value of the droop limiter assembly may be no more than three-quarters of an inch (3/4") at 1,200 lbs. The procedure: preload 100 lbs. zero (0) distance, pull to a value of 1,200 lbs.

**Torque Control Devices:** Lift arm assemblies and pull bars will be permitted. Only one (1) torque control device may be used. Lift arms must attach to the axle housing using a mounting configuration that prevents any movement between the lift arm and the rear axle housing. A gusset or brace bar to prohibit side-to-side flex will be permitted. The forward end of the lift arm may use a spring over shock assembly (5th coil), a spring or bushing, and a limiting chain. Pull bars may be adjustable on both ends; however, the adjustments must remain fixed during competition. Adjustors within reach of the driver will not be permitted.

### Rear Springs:

Coil springs or leaf springs will be permitted. Coil springs must be manufactured from magnetic steel. Leaf springs must be manufactured from either magnetic steel or approved composite material. Spring preload adjustments for coil springs must be made using mechanical adjusting nuts on the shock body. Spring preload adjustments for leaf springs must be made using a mechanical adjusting device such as an adjustable shackle or threaded rod type mount. Other than spring dampening by the shock absorber, hydraulic, pneumatic, or electrically controlled adjusting devices, (static or dynamic) that affect spring preload or race car heights will not be permitted.

## 22. ROLL CAGE

All cars must have a roll cage fabricated from a minimum 1-1/2" outside diameter, .065"-inch thick seamless DOM magnetic steel tubing. The side roll bars and/or door bars must extend into the door panels. A minimum of three-1.5" outside diameter, .065 thick bars must be utilized on the left side of the car in the door area. Any of the bars that are utilized for the top portion of the roll cage, including, but not limited to the front and rear hoops, the top hoop and the uprights, must extend a minimum of 1"-inch above the driver's helmet. All new frames and/or roll cages built on or after January 1st, 2006 an additional vertical side brace is required on the left side in vertical alignment with the steering wheel.

## 23. DRIVER SIDE INTRUSION PLATES

A minimum 1/8" (.125") thick magnetic steel intrusion plate on the driver's side door bars is mandatory.

Approved installations:

Welded plates-Individual plates between door bars are permitted but must be weld around the perimeter of each opening. Minimum area covered is 16" by 16".

A minimum of 16" by 26" plate bolted to fabricated 1/8" (.125) magnetic steel tabs, welded securely to the chasses, using a minimum of eight (8) x 3/8" Allen button head bolts required across the top of the intrusion plate, a minimum of three (3) fabricated 1/8" (.125") magnetic steel tabs and 3/8" Allen button head bolts required across the bottom of the plate, and one (1) fabricated 1/8" (.125") magnetic steel tabs and 3/8" Allen button head bolt in each in the middle front and middle rear of intrusion plate.

A minimum of 16" x 26" plate bolted to a minimum of six (6) approved-design door bar clamps using the included 12 x 1/2" Allen button head bolts per the manufacturer's specification. A minimum of three (3) approved-design door bar clamps and the included six (6) x 1/2" Allen button head bolts required across top of the intrusion plate and three (3) approved-design door bar clamps and included six (6) x 1/2" Allen button head bolts required across top of the intrusion plate and three (3) approved-design door clamps and included six (6) x 1/2" Allen button head bolts required across bottom of intrusion plate. Vendor and part number must be clearly labeled on part.

Current approved design door bar clamps (as of December 1, 2018) – in order of submission:

- Bicknell Racing Products – Part Number: BRP 954
- Wehrs Machine & Racing Products – Part Number WM397
- Allstar Performance – Part Number: ALL4198

No other manufacturer has submitted a design for approval at this time.

## 24. STEERING COMPONENTS

Only one power steering pump allowed. Electronic steering or electronic steering components will not be permitted.

## 25. WHEELS

Only steel or aluminum wheels will be permitted for competition. Fasteners on wheel discs must be taped over to ensure the fastener does not un-fasten. The wheels must be mounted to the hubs utilizing racing / safety lug nuts. "Knock off" and/or single type wheel mounting systems will not be permitted. The maximum wheel width that will be permitted is 14"-inches. The maximum front track width will be 90"-inches and the maximum rear track width will be 88"-inches, measured from the outside edge of the tire to the outside edge of the tire. **Only aluminum wheel** spacers will be permitted provided the track width(s) do not exceed their maximum dimensions. Wheel/Air Bleeders are not allowed anywhere on the car.

The combined weight of the wheel, wheel hardware, wheel disc and fasteners, and tire must not exceed 40 pounds.

## 24. TIRES

**Only American Racer AR56 27.5/11.0-15DT, 28.5/11.0-15DT, & 29.0/11.0-15DT Tires, with the MARW stamp, or PRO 3SPEC JPED6 – 88 or Pro 3SPEC JPE2A – 92, will be allowed for regular race nights. No other tires will be allowed on any corner of the car.**

There will be a tire hoop used for inspection and the tire must pass through the tire hoop freely, without any manipulation or outside contact. Tire changes will not be permitted once a car has been presented to the starting grid/lineup area for any race. Any cars making a tire change will forfeit their assigned starting position for that particular race and start from the rear of the field.

Chemical alterations, vulcanizing, tire softening, defacing and/or altering the face of the tire lettering and/or tire stamping will not be permitted. Chemicals or tire softening is not permitted at any time. Tires may be inspected at any time. Tires will be subject to a durometer test. Your tires must be harder than the baseline determined by MICHIGAN DIRT TRACK officials. Any violation with any tire presented for competition may result in immediate disqualification from the events and/or other penalties including but not limited to; loss of money, fine, loss of points and/or suspension. Only approved tires will be permitted for use in competition.

## **25. ELECTRICAL SYSTEMS, BATTERES & ELECTRICAL ACCESSORIES:**

The battery must be securely mounted with positive fasteners and brackets. The battery terminals must be insulated or enclosed with a non-conductive material that will prevent contact with any part of the race car should the battery become dislodged from the battery mount.

One (1) mandatory battery disconnect switch must be installed on the rear deck, behind the driver seat, in a location that is easily accessible from outside the race car. The switch must be clearly labeled with off/on direction. The switch must be directly in-line with the NEGATIVE battery cable and be capable of completely disconnecting the NEGATIVE terminal of the battery from the race car. Negative or "ground" wiring connections must not be made anywhere from the battery negative terminal to the input side of the disconnect switch. An additional battery disconnect switch within the drivers reach may also be used.

All battery supports and/or mounts must be secure and braced in two horizontal positions and one vertical position.

## **26. SAFETY EQUIPMENT**

Rules apply at all times car is on track. Snell-rated SA2010 or SA2015 helmet required. Roll bar padding required in driver compartment. *Recommended: Fire retardant padding.* SFI-approved full fire suit required. SFI approved driver gloves, shoes and neck brace (or head and neck restraint) required. **Competitors under the age 18 are recommended to use an SFI 38.1 head and neck restraint system due to the young body and developing bones.** Right and left seat head supports required if using head and neck restraint system. Full containment seats meeting or exceeding SFI 39.2 specification are recommended. *Recommended: Fire retardant head sock and underwear, collapsible steering shaft.* **Driver-side window net required if full containment seat and is not used, SFI arm restraints are recommended if no window net is used,** minimum 18-inch by 18-inch ribbon or mesh style, and must be mounted to roll cage so latch is at top front of window. Minimum three inch (two inch with head restraint system) wide SFI-approved five-point safety belt assembly required, must be mounted securely to main roll cage. *Recommended: Safety belts no more than two years old.* Fire suppression systems meeting or exceeding SFI 17.1 specifications are recommended.

**27. Tow chains or straps recommended. This is you choosing where your car is hooked for towing. If chains or straps are not used Crystal Motor Speedway, I-96 Speedway, Thunderbird Raceway and its officials, wrecker drivers, or any other employee or volunteer will not be responsible for damage done to the racecar while towing, hooking, unhooking or flipping over a rollover.**

## 27. BODY DRAWINGS 1 – Top View.

- 1.3a – Roof length must be a minimum of fortyfour inches (44") to a maximum of fiftyfour inches (54").
- 1.3b – Roof width must be a minimum of fortyeight inches (48") to a maximum of fiftytwo inches (52").
- 1.4a – All roof side panels must extend to edge of decking.
- 1.5f – Front fender flares cannot extend beyond front tire more than one inch (1") in width with the wheels pointing straight.
- 1.6a – Door cannot exceed seventy-six inches (77") in its entirety at top of door.
- 1.6b – Door cannot exceed ninety inches (90") in width at the bottom in the center of car.
- 1.7b – The quarter panels cannot exceed seventy-six inches (76") in width at any point behind the center of the rear hub as measured at the top.
- 1.7c – Rear decks must taper from seventy -six inches (76"), as measured at the top over the rear hubs, uniformly back to seventy-two inches (72") at the spoiler, equally on both sides.
- 1.7d – Four inches (4").
- 1.8d – Maximum spoiler width is seventytwo inches (72").

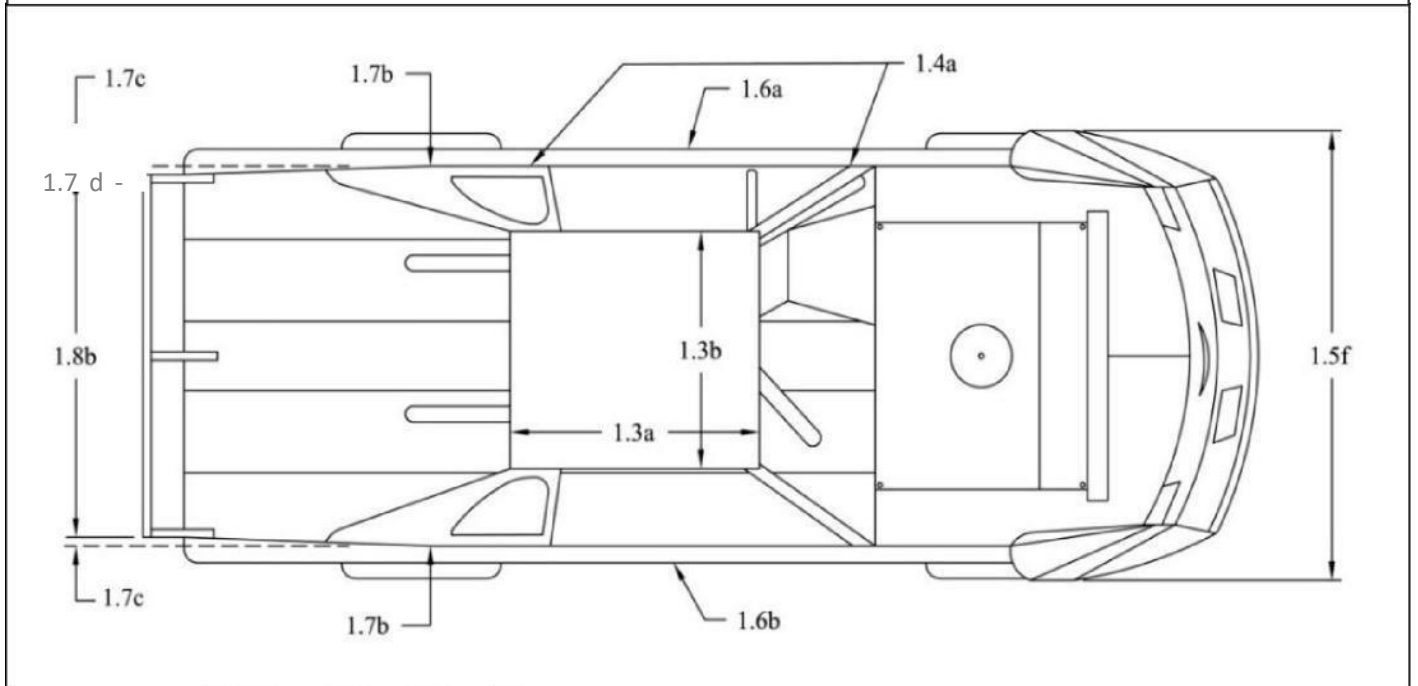

2 – Side View

- 1.2c – Stock Nosepiece can extend a maximum of **fifty-two inches (52")** from center of front hub to farthest point extending forward.
- 1.3d – Roof height must be between **forty-five inches (45")** and **forty-eight inches (48")** from the ground.
- 1.5d – Front fenders may not exceed **thirty-seven inches (37")** in height measured from the ground.
- 1.6c – Doors cannot exceed **thirty-seven inches (37")** in height measures from the ground.
- 1.7a – **Fifty-two inches (52")** maximum center of rear hub to top corner of quarter panel.
- 1.7f – **Forty eight inches (48")** maximum length from center of rear hub to end of quarter panel.
- 1.7h – Minimum of two inches (2") tire clearance from body.
- 1.7l – Any skirting cannot extend beyond the quarter panel.

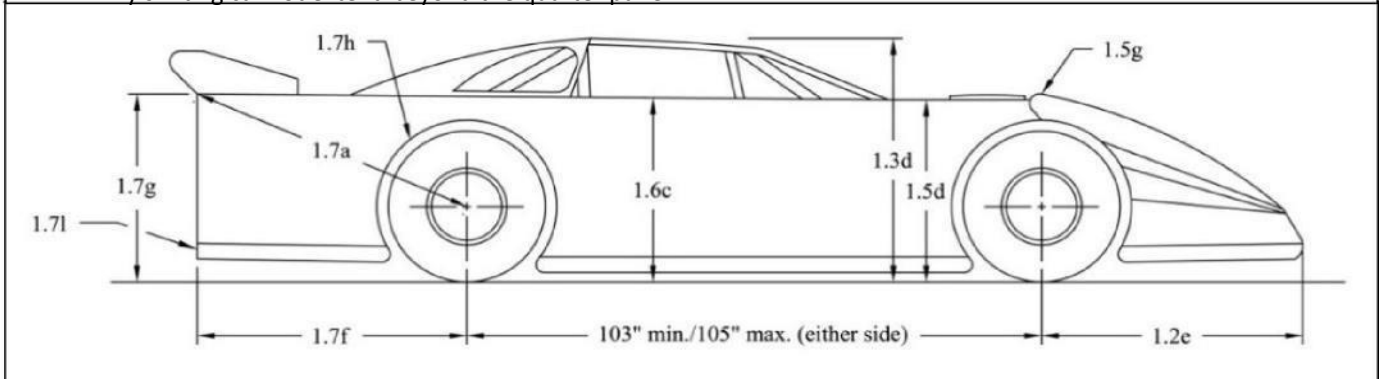

3 – Spoiler Support

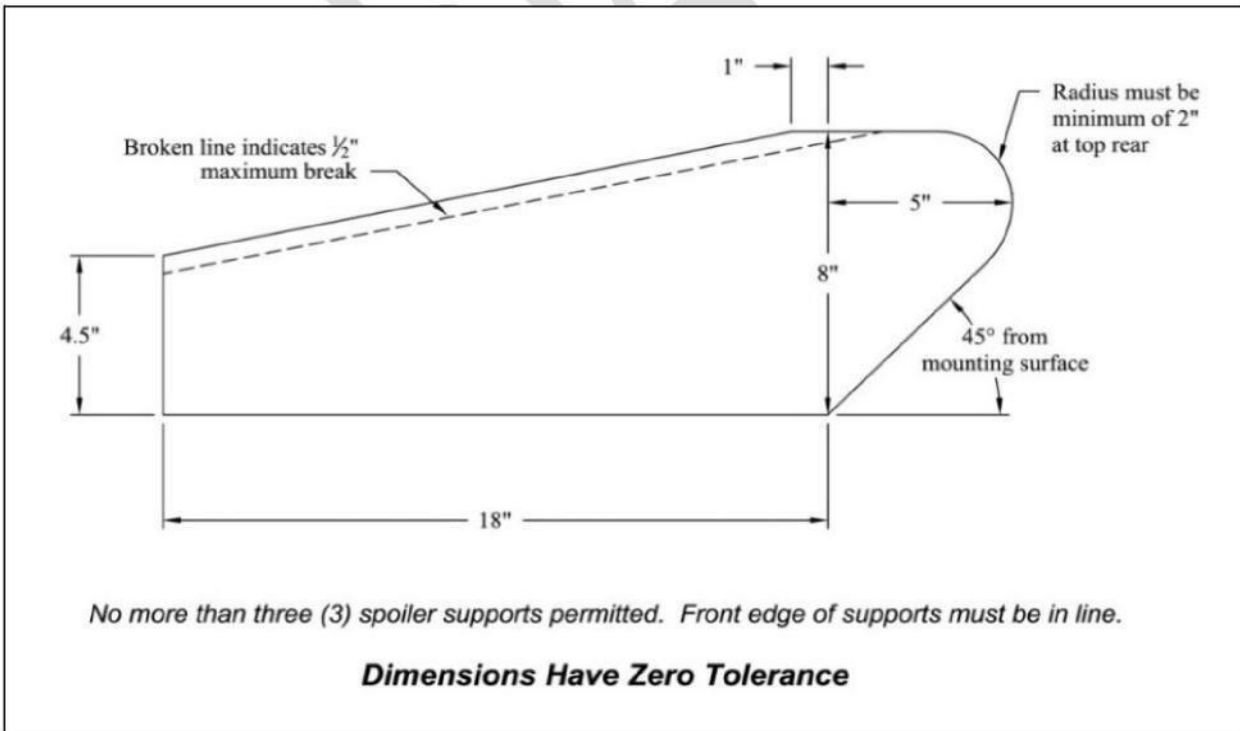

#### 4 – Rear Quarter Panel Options

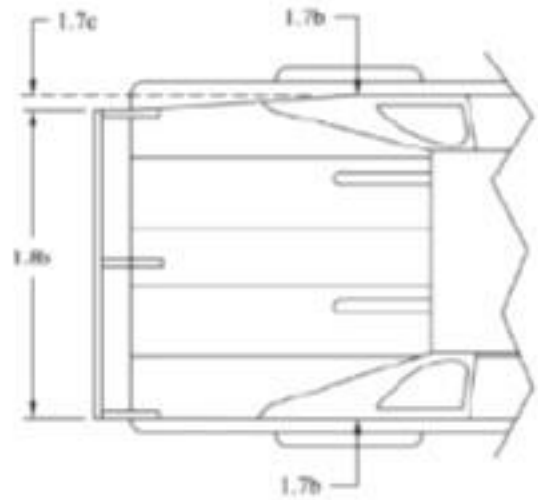
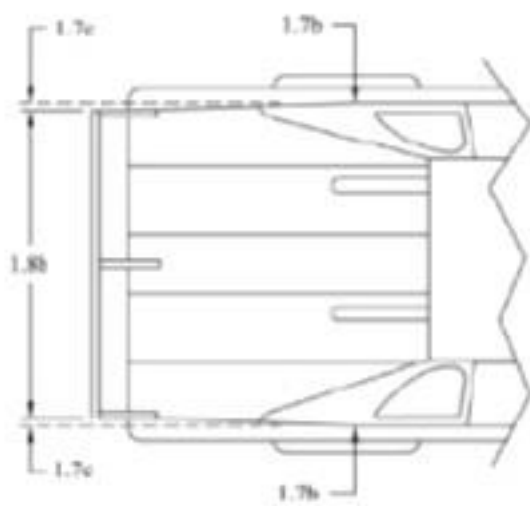

##### Option 1

Rear decks must taper from seventy-six inches (76"), as measured at the top over the rear hubs, uniformly back to seventy-two inches (72") at the spoiler, equally on both sides.

##### Option 2

Rear decks must taper from seventy-six inches (76"), as measured at the top over the rear hubs, uniformly back to seventy-two inches (72") at the spoiler, on the left side only.

#### **28. QUARTER PANELS**

A. The maximum distance from the center of the rear hub to the top quarter of the panel at the trailing edge is 54 inches.

#### **29. Spoilers and Spoiler Braces/Supports**

A. The rear spoiler must begin at the deck and extend 8-1/4" from that point. Mounting hardware, hinges, etc. will be included in the 8-1/4" measurement. Suspending the spoiler to create a wing-type device will not be permitted.

#### **30. Rear Suspension & Suspension Components**

##### Rear Travel Limiter (Droop Rule)

a. A vertical travel limiting chain must be installed on the left rear of the car from the left rear axle housing to the frame. The travel limiting chain must attach to a bearing type mount or a clamp mounted bracket with the chain mounted to the top (12 o'clock) of the left rear axle tube, between

the birdcage and the edge of the left rear bell of the axle housing, and to the left rear frame directly above the chain mount on the rear axle. Travel limiting chains must be installed so that when taunt they are as close to vertical as possible. One (1) compliance device may be used. The compliance device must not be more than one inch (1") thick (without a load applied) and remain completely open and visible. Compliance devices can be rubber or any like material but must not be installed in any type of canister. Springs, spring-loaded, and/or pneumatic devices will not be permitted. No tapered, beveled, or roller skate type of compliance rubber will be permitted. Compliance devices must be solid material, same diameter top to bottom, not hollowed or drilled to soften the material.

**b.** The travel limiting chain including the compliance rubber must be installed so that when the car is jacked up from the rear the chain assembly is tight (no slack). The travel limiting chain is subject to inspection at any time during the event at the discretion of the officials. Cars will be jacked up on the under-slung frame rail between the center of the rear axle and the Panhard bar mount. The left rear under-slung rail must be located between the left rear birdcage and the edge of the left rear axle housing bell. If a chassis is not of the under-slung design, then the car will be jacked up on the left rear frame rail closest to the Panhard bar mount. Cars will be jacked up until a forty-thousandths of an inch (.040") shim will slide between the left rear tire and the ground. Once the car is jacked up as described a vertical measurement will be taken from the ground to the top trailing edge of the rear deck bar, six inches (6") inboard of the left rear quarter panel outer edge. The measurement must not exceed fifty-one inches (51"). (Cars without a left rear underslung must not exceed fifty inches (50")).

**c.** All droop limiter assemblies must support the unsprung mass of the rear-end. The stretched value of the droop limiter assembly may be no more than three-quarters of an inch (3/4") at 1,200 lbs. The procedure: preload 100 lbs. zero (0) distance, pull to a value of 1,200 lbs.

**Penalties for failing this rule:**

1. UNDERSLUNG CHASSIS WILL HAVE A MAXIMUM ALLOWED MEASUREMENT OF 51". ANYTHING OVER THAT WILL RESULT IN DISQUALIFICATION, NO POINTS, NO PAY, NO TROPHY OR AWARDS FOR THAT EVENT.
2. OVERSLUNG CHASSIS WILL HAVE A MAXIMUM ALLOWED MEASUREMENT OF 50". ANYTHING OVER THAT WILL RESULT IN DISQUALIFICATION, NO POINTS, NO PAY, NO TROPHY OR AWARDS FOR THAT EVENT.

a